

PAN1781

Bluetooth® Low Energy Module



[OVERVIEW]

The PAN1781 is a Bluetooth 5.3 Low Energy (LE) module based on the Nordic nRF52820 single chip controller.

The Bluetooth 5.3 features additionally a higher symbol rate of 2 Mbps using the high speed LE 2M PHY or a significantly longer range using the LE coded PHY at 500 kb/s or 125 kb/s. The new channel selection algorithm (CSA#2) improves the performance in high interference environments. Furthermore, the new LE advertising extensions allow for much larger amounts of data to be broadcasted in connectionless scenarios.

An output power of up to 8 dBm and the high sensitivity of the nRF52820 in combination with the LE coded PHY make the module very attractive in applications, where a long range is required.

In addition, the ultra-low current consumption of the PAN1781 makes the module an ideal choice for battery powered devices.

With the Cortex®-M4 processor, 32 kB RAM, and the built-in 256 kB flash memory, the PAN1781 can easily be used in standalone mode, thereby eliminating the need for an external processor, saving complexity, space, and cost.

The PAN1781 also supports angle of arrival (AoA) and angle of departure (AoD) direction finding using Bluetooth.

A 128-bit AES/ECB/CCM/AAR co-processor may be used for on-the-fly packet encryption.

[FEATURES]

- Surface mount type dimensions: 15.6 mm × 8.7 mm × 2 mm
- Drop-in replacement for PAN1026A and PAN1762
- Nordic nRF52820 featuring ARM® Cortex-M4 with 64 MHz
- Bluetooth 5.3 LE including LE 2M and LE Coded PHY
- Embedded 256 kB flash memory and 32 kB internal RAM
- 128-bit AES/ECB/CCM/AAR co-processor
- Up to 16× General Purpose I/O's (GPIO), which are shared with up to 2× SPI, 2× I²C, UART, COMP, QDEC, nRESET
- USB 2.0 full-speed device interface
- Built-in temperature sensor
- APPROTECT variant available

[BLOCK DIAGRAM]

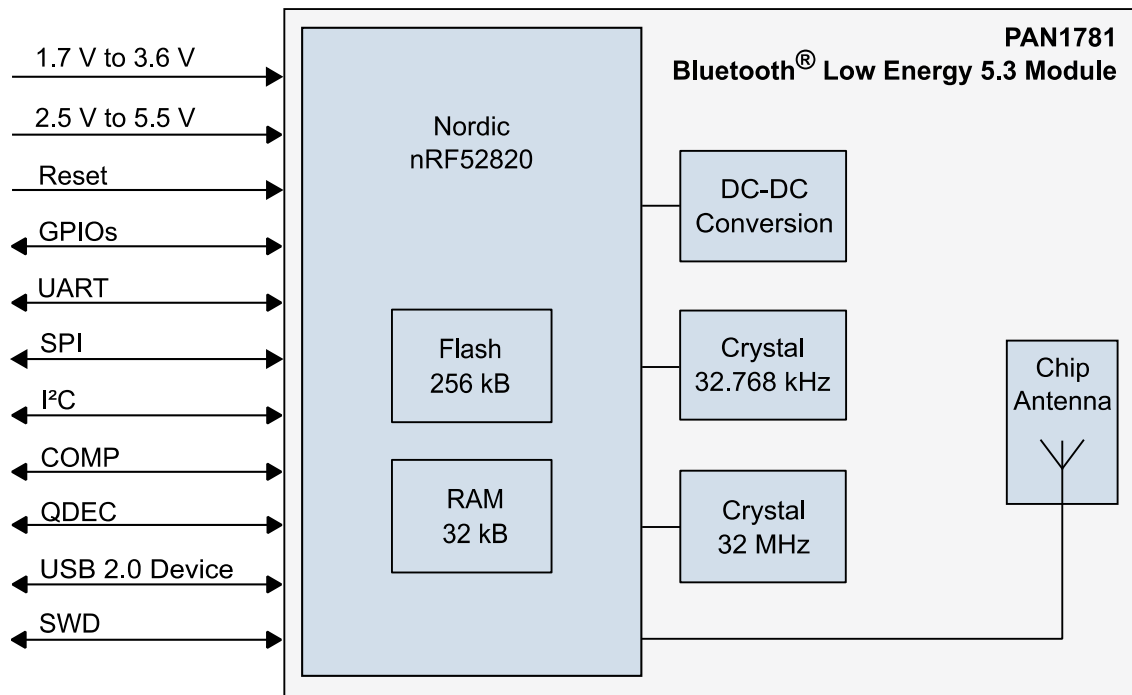

[BLUETOOTH]

- LE 2 Mbps high speed PHY, LE long range coded PHY
- LE advertising extensions (advertising on 40 channels total)
- Channel selection algorithm #2
- LE secure connections
- Angle of arrival (AoA) and angle of departure (AoD) direction finding

[TECHNICAL CHARACTERISTICS]

- Typical sensitivity: -95 dBm at 1 Mb/s and -103 dBm at 125 kb/s
- Output power: up to 8 dBm (configurable from -20 dBm in 4 dB steps and -40 dBm in whisper mode)
- Typical current consumption: 4.9 mA in Tx (at 0 dBm) and 4.7 mA in Rx mode
- Typical current consumption: 0.3 μ A in System OFF mode, 1.2 μ A with RTC wake up
- On-module DC-DC and LDO regulators with automated low current modes
- Voltage range: 1.7 V to 5.5 V
- Temperature range: -40 $^{\circ}$ C to 85 $^{\circ}$ C