

PAN1780

Bluetooth® Low Energy Module

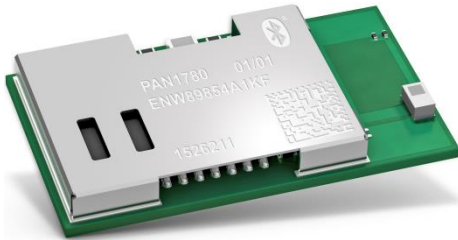

[OVERVIEW]

The PAN1780 is a Bluetooth 5 Low Energy (LE) module based on the Nordic nRF52840 single chip controller. Besides Bluetooth® 5 with the qualified Bluetooth® mesh profile stack it supports 802.15.4 ZigBee and Thread as well as NFC-A.

The Bluetooth 5 features additionally a higher symbol rate of 2 Mbps using the high speed LE 2M PHY or a significantly longer range using the LE coded PHY at 500 kb/s or 125 kb/s. The new channel selection algorithm (CSA#2) improves the performance in high interference environments. Furthermore, the new LE advertising extensions allow for much larger amounts of data to be broadcasted in connectionless scenarios.

An output power of up to 8 dBm and the high sensitivity of the nRF52840 in combination with the LE coded PHY make the module very attractive in applications, where a long range is required.

In addition the ultra low current consumption of the PAN1780 makes the module an ideal choice for battery powered devices.

With the Cortex® M4F processor, 256 kB RAM and the build in 1 MB flash memory the PAN1780 can easily be used in standalone mode, thereby eliminating the need for an external processor, saving complexity, space, and cost.

The rich set of security features from the ARM® TrustZone® CryptoCell 310 security subsystem provide the necessary means for secure device operation in the IoT space.

The PAN1780 also supports Type 2 Near Field Communication (NFC A) for use in simplified pairing and payment solutions (external antenna required).

[FEATURES]

- Surface mount type dimensions: 15.6 mm x 8.7 mm x 2.1 mm
- Same form factor as PAN1026A and PAN1762 but smaller pitch and more pins
- Nordic nRF52840 featuring ARM Cortex-M4F with 64 MHz
- Bluetooth 5 LE including LE 2M and LE Coded PHY
- 802.15.4 Zigbee & Thread support
- Embedded 1 MB flash memory and 256 kB internal RAM
- Includes ARM TrustZone CryptoCell 310 and supports secure boot including Root of Trust (RoT)
- Up to 48 General Purpose I/Os (GPIO), which are shared by up to 4 SPI, 2 I²C, 2 UART, 4 PWM, 8 ADC, 1 NFC-A, 32 kHz IN/OUT, nRESET
- USB 2.0 full-speed device interface
- Built in temperature sensor

[BLOCK DIAGRAM]

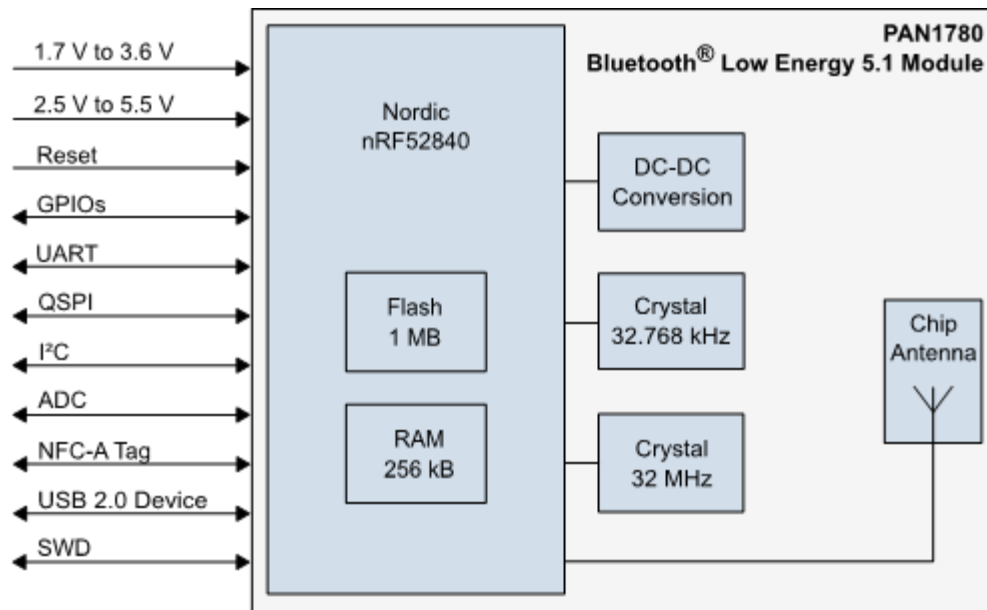

[BLUETOOTH]

- LE 2 Mbps high speed PHY, LE long range coded PHY
- LE advertising extensions (advertising on 40 channels total)
- Channel selection algorithm #2
- LE secure connections
- Over-the-air update of application software
- Qualified Bluetooth mesh profile stack

[TECHNICAL CHARACTERISTICS]

- Typical sensitivity: -95 dBm at 1 Mb/s and -103 dBm at 125 kb/s
- Typical max. output power: 8 dBm, configurable from -20 dBm in 4 dB steps and -40 dBm in whisper mode
- Typical current consumption: 4.8 mA in Tx (at 0 dBm) and 4.8 mA in Rx mode
- Typical current consumption: 0.4 μ A in System OFF mode, 1.5 μ A with RTC wake up
- On-module DC/DC and LDO regulators with automated low current modes
- Voltage range: 1.7 V to 5.5 V
- Temperature range: -40 °C to 85 °C